

DO NOT SCALE - IF IN DOUBT ASK

- NOTE:
- DN80 FLANGE ON SOCKET TEE
 - DN80 GATE VALVE (AS CLOSE TO TEE AS POSSIBLE)
 - DN80 FLANGE ADAPTOR
 - DN80 HYDRANT DUCKFOOT BEND
 - DN80 DOUBLE FLANGED RISER PIECE(S) IN STANDARD LENGTHS
 - DN80 SCREW DOWN TYPE HYDRANT
 - DN300 BLANK FLANGE
 - DN80 FLANGE ON DN300 ALL FLANGED TEE
 - DN300 DOUBLE FLANGED RISER PIECE(S) IN STANDARD LENGTHS
 - 4550D STUDDED PLATE DRILLED TO DN300 PN16 FLANGE AND STUDDED TO SUIT DN80 PN16 FLANGE WITH CENTRE HOLE DN80
 - DN100 FLANGE ON SOCKET TEE
 - DN100 GATE VALVE (AS CLOSE TO TEE AS POSSIBLE)
 - DN100 FLANGE ADAPTOR
 - DN100 FLANGE ON DN300 ALL FLANGED TEE
 - DN200 FLANGE ON SOCKET LEVEL INVERT TEE
 - DN200 GATE VALVE (AS CLOSE TO TEE AS POSSIBLE)
 - DN200 FLANGE ADAPTOR
 - DN200 FLANGE ON DN300 ALL FLANGED TEE
 - FOR DETAILS OF CHAMBERS REF DRG AM-DRG-WN-02211
 - CONCRETE SUPPORT BLOCK
 - THRUST BLOCKS ONLY REQUIRED IF END LOAD RESISTANT JOINTS ARE NOT USED
 - DN200 NON RETURN VALVE
 - DN200 PIPEWORK
 - DN200 FLAP VALVE
 - PE ELECTROFUSION DUCKFOOT BEND KIT. RISER CUT TO SUIT
 - PE BUTT WELDED TEE WITH FLANGED BRANCH
 - THE HYDRANT AND VALVE SHALL BE INSTALLED SUCH THAT THEY ARE TRULY PLUMB

- GUIDANCE NOTE
- THIS DRAWING DETAILS BEST PRACTICE AND SHALL BE ADHERED TO WHERE EVER PRACTICABLE. DEROGATION OF THE CONTENT ON INTENT OF THIS DRAWING REQUIRES WRITTEN CONSENT FROM THE TECHNICAL LEAD.
 - FOR GUIDANCE ON PIPE MATERIAL SELECTION SEE TW WATER MAINS DESIGN STANDARD
 - IN FIELD, RAISED CHAMBER AND/OR FENCING MAY BE APPROPRIATE - LAND OWNER AGREEMENT REQUIRED.
 - CHAMBER STRUCTURAL DETAILS SHALL BE CHECKED FOR EACH APPLICATION
 - CHAMBER SHALL BE INSTALLED IN ACCORDANCE WITH MANUFACTURER'S INSTRUCTIONS
 - WHERE APPLICABLE ALL MATERIALS SHALL BE FROM THAMES WATER FRAMEWORK SUPPLIERS
 - EXTERNAL PROTECTION FOR BURIED FLANGED JOINTS, FLANGE ADAPTOR AND COUPLINGS SHALL BE TYPE P1 AS DEFINED IN CLAUSE 5.14 OF CESW 6TH EDITION. THIS PROTECTION SHALL COVER THE FLANGE AND ALL NUTS, BOLTS AND THREADS.
 - DUE TO THE RISK OF CONTAMINATION PERMANENT CONNECTIONS TO SEWER SHALL BE AVOIDED

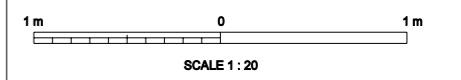

DATA OWNER	ASSET MANAGEMENT STANDARDS MANAGER
TECHNICAL LEAD (S)	MICHAEL BRIGHT
DOCUMENT AUTHOR	TECHNICAL INFORMATION
AUTHORISED BY	STANDARDS BOARD
DOCUMENT LOCATION	AM STANDARDS
DATE OF ISSUE	30/09/2013
REASON FOR ISSUE	CONVERSION AND REISSUE
REVIEW DATE	30/09/2015



Location Code:	OS Reference:	Security Reference:	Drawn By:
Project Group:	Sub Process:		
TECHNICAL STANDARDS			
Location / Town:			
Site Name:			
Project Name: STANDARD DRAWINGS - MANDATORY			
Contract Name: WATER NETWORK			
Drawing Title: OFFLINE PIPEWORK DETAILS FOR WASHOUT, DISINFECTION POINT AND HYDRANTS			
Drawing No.:	Scale:	Sheet Size:	Rev:
AM-DRG-WN-02213	1:20	A1	1.0

A

B

C

D

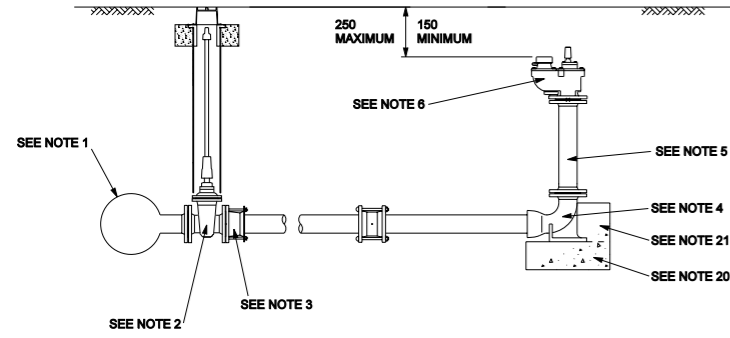

OFFLINE - WASHOUT
≤ DN300
ISOLATING VALVE CLOSED

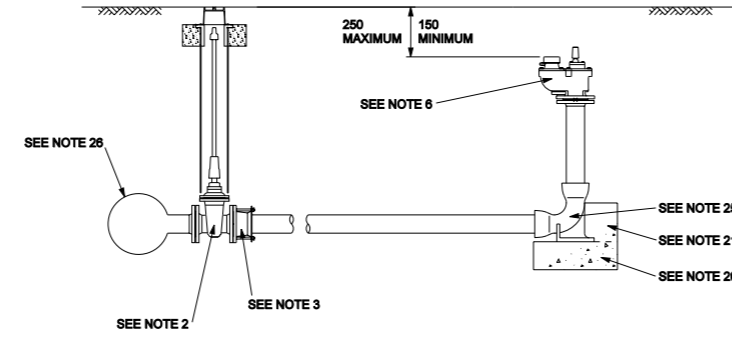

OFFLINE - WASHOUT
≤ PE OD355
ISOLATING VALVE CLOSED

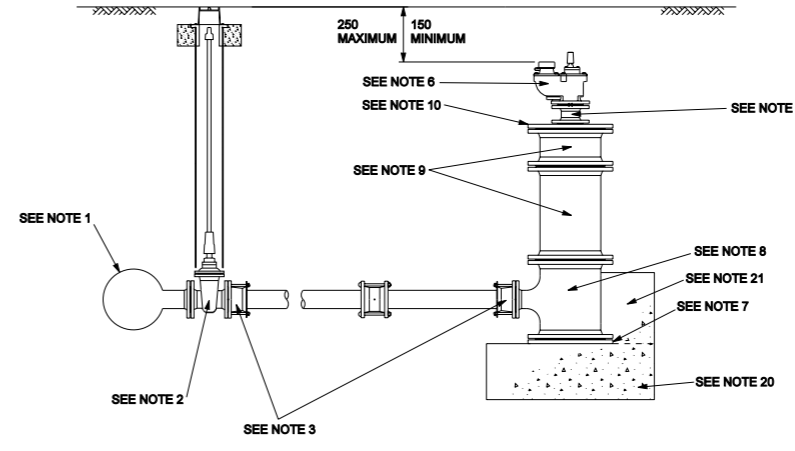

OFFLINE - WASHOUT
>= DN200 ≤ DN300
(ALTERNATIVE)

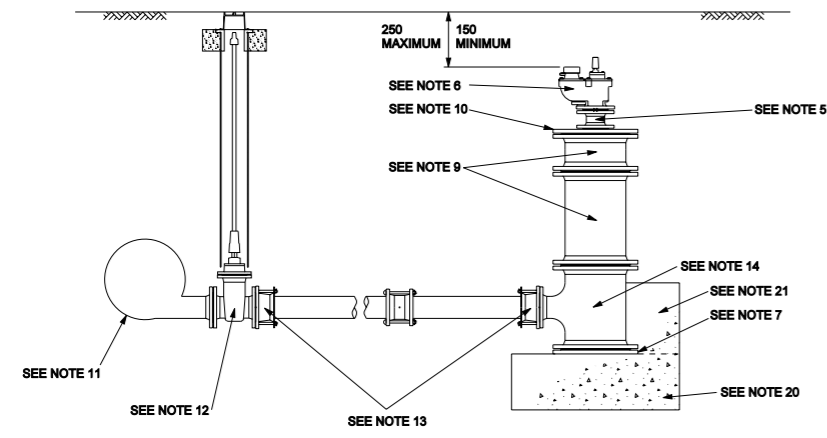

OFFLINE - WASHOUT
> DN300
≤ DN600

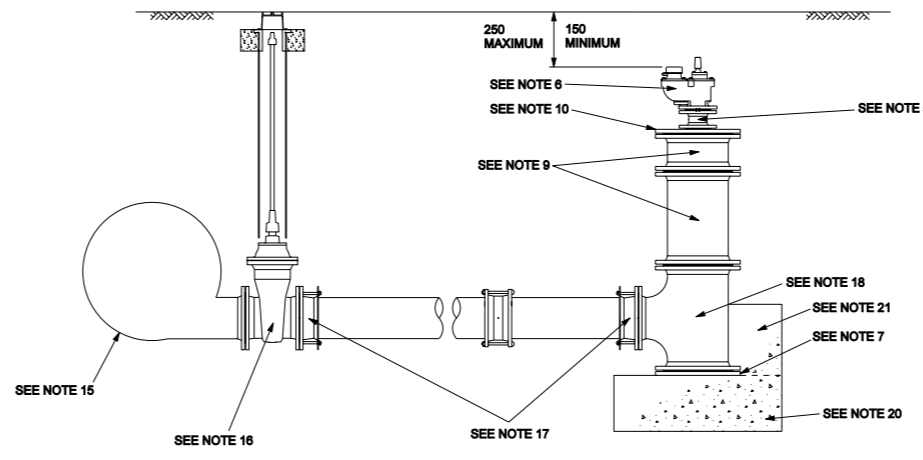

OFFLINE - WASHOUT
> DN600

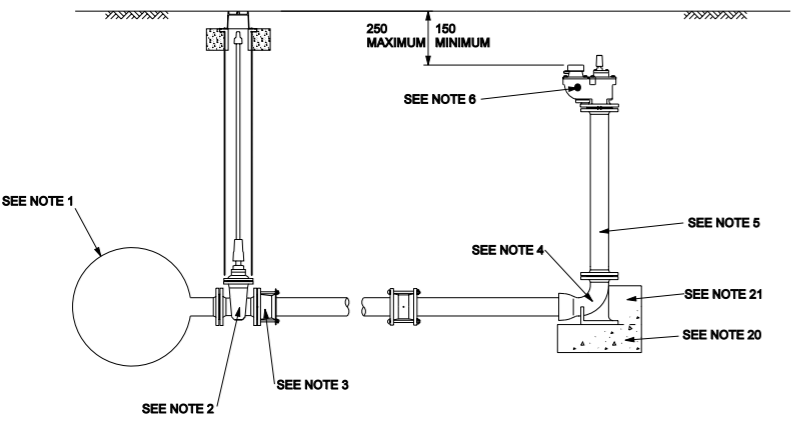

OFFLINE - FIRE HYDRANT
≤ DN600
ISOLATING VALVE OPEN

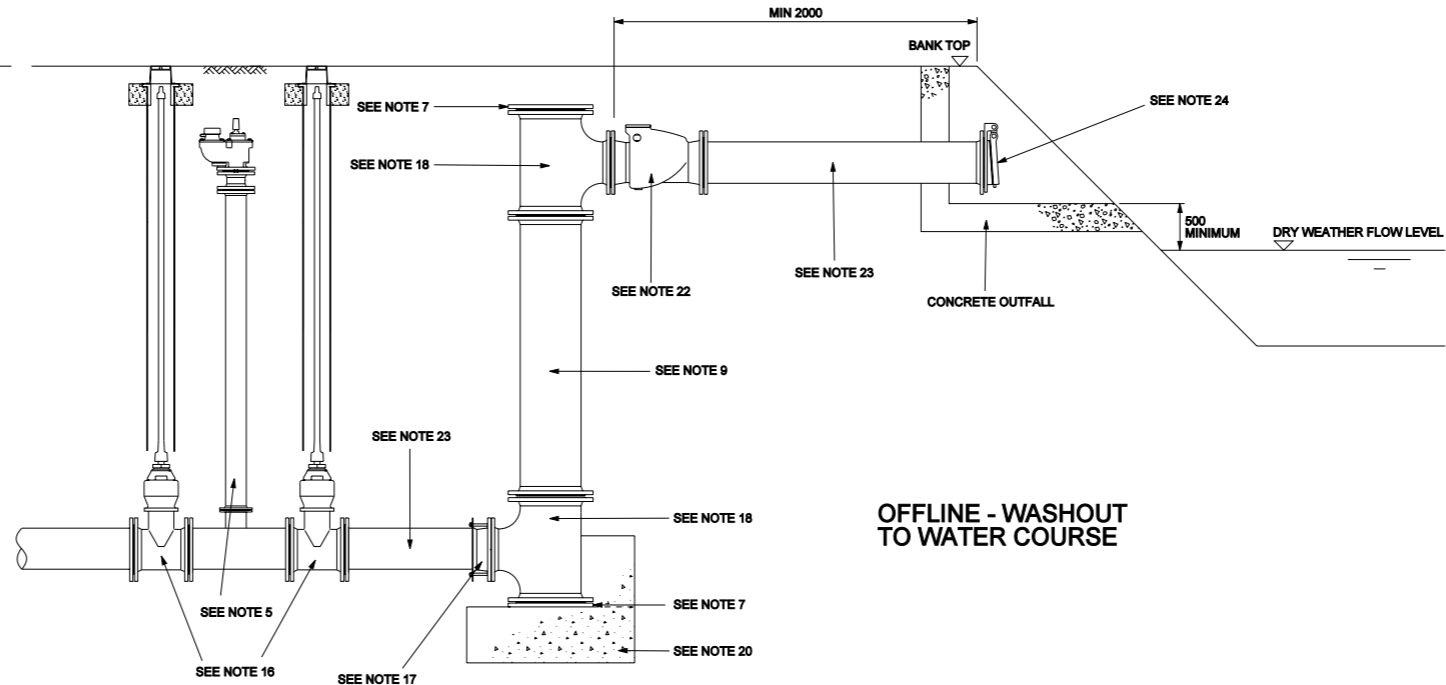

OFFLINE - WASHOUT TO WATER COURSE

NOTE: CHAMBER DETAILS OMITTED FOR CLARITY SEE DRG No.AM-DRG-WN-02211